

**UNIVERSITY COLLEGE TATI (UC TATI)****FINAL EXAMINATION QUESTION BOOKLET**

COURSE CODE	:	BMT 1203
COURSE	:	ELECTRICAL & ELECTRONICS
SEMESTER / SESSION	:	01 - 2022/2023
DURATION	:	3 HOURS

**Instructions:**

1. This booklet contains **4** questions. Answer **ALL**.
2. All answers should be written in the answer booklet.
3. Write legibly and draw sketches wherever required.
4. If in doubt, raise your hand and ask the invigilator.

**DO NOT OPEN THIS BOOKLET UNTIL YOU ARE TOLD TO DO SO**

**THIS BOOKLET CONTAINS 5 PRINTED PAGES INCLUDING COVER PAGE**

**QUESTION 1**

- a) When a capacitor is connected to a circuit with a DC supply, two processes called charging and discharging occur.
- Show suitable circuit diagrams of the charging process of a capacitor. (4 marks)
  - Explain the charging process of a capacitor based on each diagram. (6 marks)
- b) Based on the capacitor circuit as shown in Figure 1:

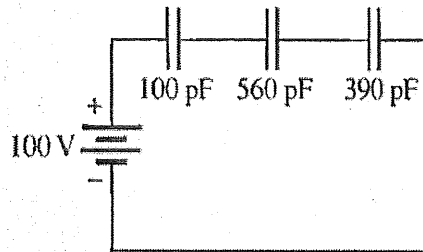

Figure 1

- State the type of circuit arrangement. (1 mark)
  - Determine the total capacitance of the circuit. (3 marks)
- c) An inductor is an electrical component which stores the electrical energy in the magnetic field.
- Show suitable diagrams of the basic operation of an inductor. (2 marks)
  - Describe the basic operation of an inductor. (8 marks)
- d) Based on the inductor circuit as shown in Figure 2:

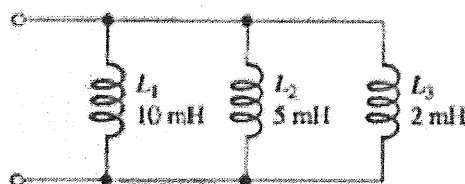

Figure 2

- State the type of circuit arrangement. (1 mark)
- Determine the total inductance of the circuit. (3 marks)

**QUESTION 2**

a) Explain the advantages of three-phase AC power over single-phase AC power.

(6 marks)

b) Based on the three-phase circuit as shown in Figure 3:

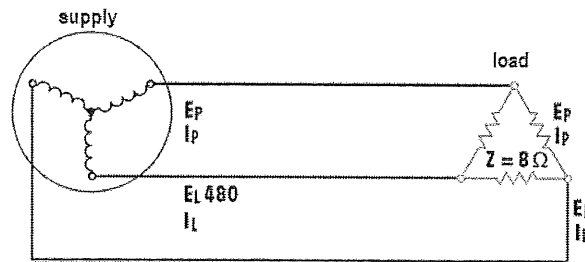

Figure 3

i) State the connection of the supply. (1 mark)

ii) State the connection of the load. (1 mark)

iii) Determine the value for the phase current of the load. (3 marks)

iv) Determine the value for the load current of the load. (3 marks)

c) Explain the formation of the depletion region at the PN junction of a diode using a suitable diagram and explanation. (7 marks)

d) Based on the diode circuit as shown in Figure 4:

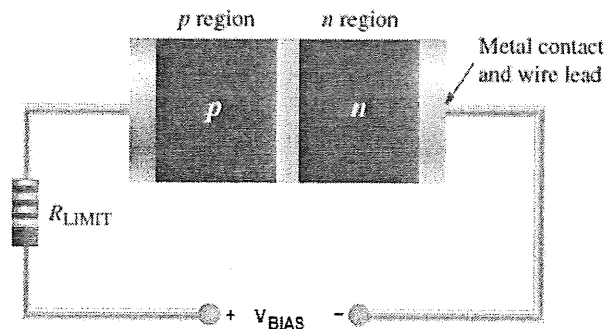

Figure 4

i) State the type of diode biasing. (1 mark)

ii) Describe the behavior of free electrons in the circuit. (6 marks)

## QUESTION 3

- a) Describe the free electron behavior of an NPN BJT using a suitable diagram and description. (7 marks)
- b) Based on the BJT circuit as shown in Figure 5:

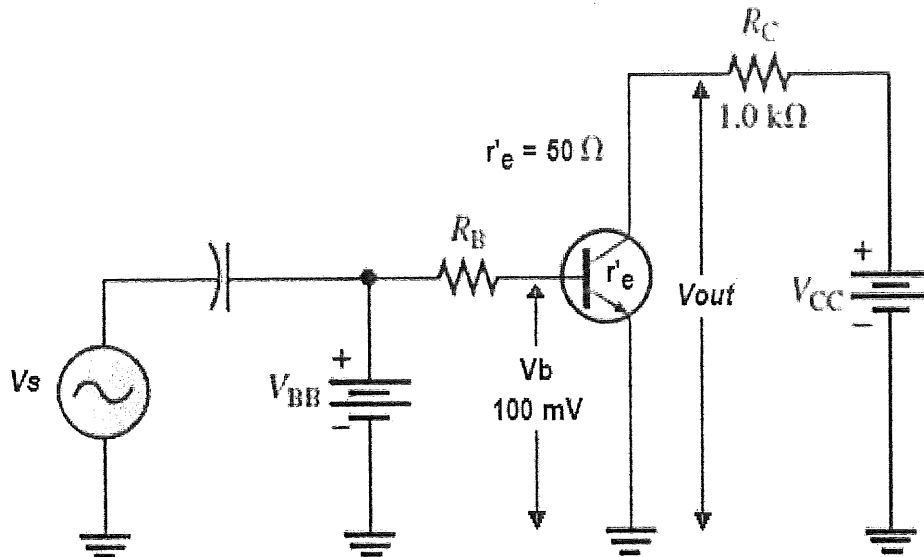

Figure 5

- i) State the biasing of the BE junction. (1 mark)
- ii) State the biasing of the BC junction. (1 mark)
- iii) State the equation for input voltage,  $V_{in}$ . (1 mark)
- iv) Determine the value for voltage gain,  $A_v$ . (2 marks)
- v) Determine the value for ac output voltage,  $V_{out}$ . (2 marks)
- c) List out the four advantages of the digital system. (4 marks)
- d) Convert the binary number  $101011_2$  to its decimal number equivalent using the sum of weight method. (3 marks)
- e) Convert the decimal number  $80_{10}$  to its binary number equivalent using the repetitive division method. (3 marks)

**QUESTION 4**

a) Based on the digital circuit as shown in Figure 6:

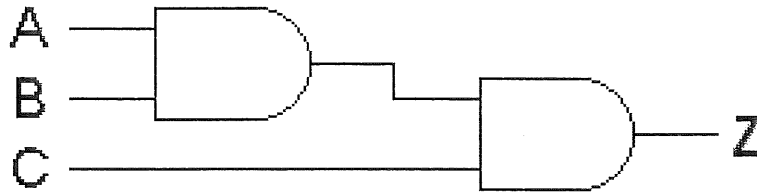

Figure 6

- i) Name the logic gate used in the circuit. (1 mark)
- ii) Determine the Boolean expression of the circuit. (2 marks)
- iii) Determine the complete truth table of the circuit. (8 marks)

b) Based on the digital circuit as shown in Figure 7:

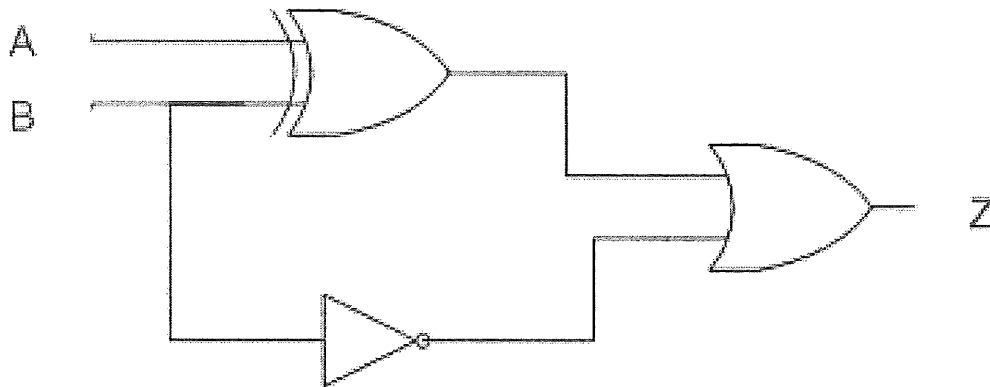

Figure 7

- i) Name the logic gates used in the circuit. (3 marks)
- ii) Determine the Boolean expression of the circuit. (2 marks)
- iii) Determine the complete truth table of the circuit. (4 marks)

-----End of Questions-----

